

# Monitoring Geothermal Heat Pump Performance

**HOB0**®  
Data Loggers

# Monitoring Geothermal Heat Pump Performance

## Introduction

The geothermal heat pump (GHP) offers one of the most effective ways to save energy and cut carbon dioxide emissions from buildings. In fact, the U.S. Environmental Protection Agency (EPA) says this appliance stands as one of the most energy efficient and environmentally-benign of our heating, ventilation, and air conditioning options. Installing geothermal heat pumps to their full potential nationwide could cut by nearly half the amount of new power generation needed by 2030.

The numbers are impressive. Geothermal heat pumps would:

- Avert construction of 91 GW to 105 GW of generation capacity, which is 42% to 48% of the 218 GW of new power the US will need in 2030
- Save \$33 to \$38 billion annually in reduced utility bills<sup>1</sup>

Yet installations of geothermal heat pumps remain relatively few. What's the problem? The energy industry needs to do a better job making the case for this valuable technology. A US Department of Energy (DOE) report says that to grow the market, the industry needs to present more hard data and analysis on system performance.

Such data would serve two purposes. First, it would underscore the technology's superiority to policy makers and consumers. Second, it would enable installers to maximize the potential of the technology.

This paper discusses how portable data logging technology can be used to measure, record, and document the performance of geothermal heat pumps, and provides specific case study examples of how the technology is being applied in geothermal system monitoring applications.

## Identity crisis

Geothermal heat pumps suffer from a bit of an identity crisis. Consumers often believe that geothermal heat pumps are unavailable for their use because they confuse the technology with power production from geothermal geysers. While the two technologies share the world "geothermal", in reality they are completely different.

Geothermal geyser technology is used for power plants in areas of underground geysers and hot springs, typically confined to parts of the country where magma is close to the Earth's surface. Steam is trapped and directed to spin turbine generators in the power plant.

Geothermal heat pumps, on the other hand, are a form of distributed energy that can be used virtually anywhere a building sits on the

ground. They do not fuel power plants, but rather, are appliances to heat and cool buildings or provide hot water.

## Operating basics

Underground temperatures are cooler than air in the summer and warmer than air in the winter, remaining between 45 and 75 degrees Fahrenheit depending on latitude. Geothermal heat pumps capitalize on this temperate underground climate, using water (or an anti-freeze solution) as a medium to transfer heat between the ground and building.

A geothermal system has three main components:

1. A series of underground pipes, called the geothermal loop
2. A heat pump unit
3. A distribution system (such as fan and duct work or a hydronic radiant floor)

The way the system operates depends on whether it is heating or cooling the building. In the heating cycle, the water circulates through the loop and extracts heat from the soil. The water flows to the heat pump unit inside the building and then passes through a heat exchanger. For air conditioning, the cycle is reversed, pulling heat out of the building.

Geothermal heat systems may be either open or closed loops. An open system often relies on well water that is drawn up to the heat exchanger. At the end of the cycle, the water goes either into a separate well, a stream, pond or gully. Closed-loop systems rely on a continuous loop of underground pipes that circulate antifreeze.

## Financial incentives

Because of their high efficiency, geothermal heat pumps are eligible for tax credits and other government incentives. On the federal level, a 10% tax credit is available for commercial systems through 2016, which also can be taken as a grant in-lieu of credit. In addition, geothermal heat pumps placed in service after October 3, 2008 are subject to a 5-year depreciation period.

Further, taxpayers can deduct the cost of some energy-efficient systems, including geothermal heat pumps, installed in commercial buildings. The deduction amounts to \$1.80 per square foot of building floor area for buildings achieving a 50% energy savings target. It is available through December 31, 2013. Homeowners who install Energy Star geothermal heat pumps can qualify for a 30% tax credit, available through 2016.

<sup>1</sup> Oak Ridge National Laboratory, Department of Energy, "Geothermal (Ground-Source) Heat Pumps: Market Status, Barriers to Adoption, and Actions to Overcome Barriers," December 2008

States also offer a range of credits, loans, and rebates for heat pumps. To find those available in your state, go to the Database for State Incentives for Renewables & Energy Efficiency: [www.dsireusa.org/](http://www.dsireusa.org/)

## Increased need for data collection

The North American geothermal market has grown dramatically in recent years. Still, the technology remains only a small part of the overall US heating and cooling appliance market. Most recent available federal data shows 86,369 units shipped in the United States in 2007. In contrast, 1,056,915 gas-fired furnaces were shipped in the first seven months of this year alone; air-source heat pumps and central air conditioners accounted for 3,353,331 shipments over the same time period, according to the Air Conditioning, Heating and Refrigeration Institute.

According to the DOE, to help spur growth in the GHP market, the industry needs to collect data that helps track, validate, and optimize system performance. Second, installers need to collect data to customize systems geography. Specifically, the DOE recommends that installers:

1. Gather statistically valid, hard data on installed costs and energy, demand, and maintenance savings versus baseline systems in existing GHP installations in major market segments (schools, federal, residential, etc.) by climate. The work must characterize not only the benefits to consumers, but also reduced peak demand and improved annual load factor.
2. Develop GHP “in the most economical manner” by developing “the engineering data, analysis, and tools to enable selection, design, specification, and construction of the lowest life-cycle-cost GHP infrastructure option as a function of varying conditions that may be encountered (drilling and trenching conditions, surface water availability, etc.) at the application’s site and scale (building, neighborhood or community.)”<sup>2</sup>

## Role of data loggers

The use of portable data loggers helps address these requirements. Data loggers are battery-operated measurement tools containing a microprocessor, memory, and sensors for measuring and recording one or more variables over time. The devices can easily and quickly be installed at key points along the geothermal system to measure air and water temperatures, water flow, electricity consumption, and soil temperatures.

Some data loggers have internal sensors so that measurements can be made within the logger, while others rely on external sensors that allow for monitoring at some distance from the data logger itself. The devices typically operate unattended for hours, days, or months at a time. Specialized software is used to configure the logger (select sam-

pling intervals, synchronize logger and computer clocks, etc.) and to later graph and analyze the collection data on a PC or Mac computer.

Essentially, two types of data loggers exist: standalone data loggers, and web-based data logging systems. Standalone data loggers, which typically connect to a computer via a USB cable, require the user to manually off-load data onto the computer, adjust configurations, and/or launch new sensors. In order to perform any of these actions, the user typically needs to travel to the site where the equipment is deployed.

Web-based data logging systems enable users to access collected data and perform system management and control functions over the Internet without having to travel to the monitoring site. These systems may feature similar sensors, hardware, and power options as their standalone counterparts, but provide the convenience of integrated remote communications technologies.

## Real-world examples

### *Geothermal heat pump performance monitoring*

The Chewonki Foundation, [www.chewonki.org/](http://www.chewonki.org/), a Wiscasset, ME-based nonprofit educational institution, uses a web-based data logging system in a pilot project funded by \$20,000 grant from the Maine Public Utilities Commission. The foundation is attempting to verify claims by manufacturers that geothermal heat pumps offer energy savings of about one-third. The test is part of the state’s effort to seek alternatives to Number 2 heating oil, and may lead to greater installation of geothermal heat pumps in public housing.

The foundation has installed a geothermal heat pump in its 11,000 square-foot meeting center, using an existing well with a flow level of about 22 gallons per minute. The unit serves radiant floor heating, installed in about one-third of the building. The center has attached sensors to various points on the geothermal system to measure air temperature, British Thermal Units, kilowatt hours, and water flow rates for the 2009/2010 heating system.

In all, Chewonki uses four temperature probes that send information to the data loggers. Two sensors measure the temperature of the well water entering and exiting the system, with the expectation that there will be a 10 degree difference. Water should enter the open-looped system at 50 degrees and after heat is extracted, exit at 40 degrees. The center uses the two additional temperature sensors to measure the outside and inside air.

A flow meter connected to the well pump measures the rate at which the water enters the system; a second sensor is attached to the radiant floor heating to see how much liquid is circulating. The remaining sensors measure the system’s kilowatt-hour consumption.

<sup>2</sup>Ibid

## WHITE PAPER SERIES

To do this, sensors are attached to the heat pump, well pump, and two flow pumps, one that circulates water through the floor and another responsible for moving water from the heat pump to the hot water tank. See figure 1.

The foundation seeks to determine the electric cost of the system, and how much it is paying to operate the geothermal system versus purchasing the gallons of heating oil for its previous system, normalized for changes in weather. A cost comparison requires mathematical conversion of the BTUs produced by the geothermal unit into gallons of Number 2 heating oil, a calculation the center will perform after the heating season is over. The center also is using the data for a comparison of carbon dioxide emissions from the two systems. For every gallon of heating oil use avoided, the center will eliminate about 24 pounds of CO<sub>2</sub> production.

Chewonki expects data processing to be relatively straightforward because of the ease the system offers in reading and graphing data transmitted via Ethernet to the web. Chewonki's system is configured to offer 15 different channels of information all displayed simultaneously on a computer screen at the center. The live data feed offers the center the added benefit of serving as an educational tool, in keeping with the foundation's mission. The foundation offers ecology camps and classes for middle and high school students, so it has configured the web page with a "public access" feature that lets faculty and students log on to see the latest measurements, as well as measurements taken over past weeks and months.

Once its test year is over, Chewonki may make changes to the system to improve its performance. For example, the foundation is experimenting with keeping down geothermal costs by using a one-well system that drains the used water at the property perimeter. Given Maine's cold winters, a concern is that the water may freeze, dam, and back up. Should this happen, the center will have to invest in a second well or direct the water elsewhere onto the property by digging a new trench, which will change the length of pay back for the system.

### Soil thermal conductivity testing

The proper configuration of a geothermal system depends upon the kind of soil the building sits on.

Major Geothermal, [www.majorgeothermal.com](http://www.majorgeothermal.com), a 10-year-old Wheat Ridge, Colorado company that designs and installs residential and commercial systems, uses data loggers for thermal conductivity tests of vertical closed loop systems. The company finds this pre-installation modeling crucial to building a successful system.

Specifically, Major Geothermal uses data loggers to calculate the average conductivity for the entire ground loop. It does this by measuring the normal ground temperature with data loggers, then inducing heat into the circuit. The heat is injected at known energy and flow rates to determine the rise in water temperature.

The test provides an average thermal conductivity value over the entire test bore length. The company uses this value, along with the undisturbed soil temperature and empirical diffusive data interpreted from the drill log, to determine the proper system design, taking into account the building's energy consumption and the heat pump performance. The value will, for example, determine the final number of bore holes required for the system, along with

minimum spacing between holes and the minimum thermal enhancement of the grout used to optimize the ground heat exchanger's performance. Major Geothermal balances the field design against the building's energy load and the required flow rates of the heat pumps. This assessment guides the designer in selecting the proper bore depth and pipe size for the field.

Depending on the constitution of the soil and moisture, the thermal conductivity value may range from a low of 0.40 BTU per hour, per cubic foot per °F to as high as 01.50+ BTU per hour, per cubic foot per °F. Whether the soil is dry or wet will determine its heat capacity. Dry soil has a heat capacity of about 0.20 BTU per pound per °F of temperature change -- only one-fifth the heat capacity of water. Moist soils have better heat capacities of about 0.23 to 0.25 BTU per pound, per °F.<sup>3</sup>

Figure 1.

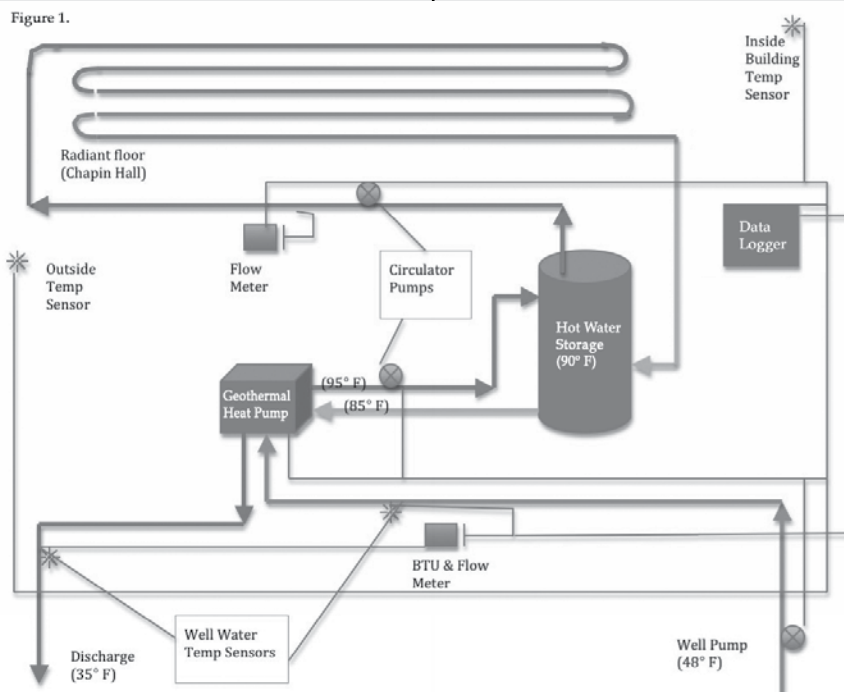

<sup>3</sup> Virginia Department of Mines, Minerals, and Energy, Geo4VA, [www.geo4va.vt.edu/indexGeo4VA.htm](http://www.geo4va.vt.edu/indexGeo4VA.htm)

## WHITE PAPER SERIES

To conduct the test, Major Geothermal attaches two sensors to the water-filled ground loop, one on the inlet to the unit and one on the outlet going back to the ground loop. The circulation pump is activated and measure is taken of average loop temperature. The heating elements are switched on and temperatures re-measured. The data logger samples every 30 seconds for 48 hours. The company also monitors the voltage and amperage. Since the pumps are water-lubricated, the heat of the pump is added in. The company calculates Voltage x Amps= kWh x 3,420BTU = total BTU .

The measurements show how well the loop dissipates heat to the ground. Conductivity is described as BTU per hour, per cubic foot, per °F. A conductivity of 0.55 may require 3,180 vertical feet of tubes, while a 1.5 conductivity only 2,110 feet. Such a variation in size can mean a nearly \$10,000 difference in the cost of a 10-ton system, if the tubing is \$9/vertical foot.<sup>4</sup>

It is important to determine thermal conductivity values for each building site and heat exchanger configuration, according to Major Geothermal. The installer should not assume that soil conductivity is the same in a given region; this leads to incorrectly sized systems, which do not perform as efficiently as possible, and therefore create sub-standard energy and cost savings. The thermal conductivity test value applies only to the specific depth of the test bore. A test bore of 300' may have a different value than, say, a 400' hole drilled in the same area.

In some cases, a thermal conductivity test may not be cost-effective, particularly for a small system. It is important that a trained designer size the system with pre-modeled data, if a test is not warranted. Sufficient knowledge of the type of heat exchanger to be used, the loads and equipment serviced by the heat exchanger, and comprehension of minimum ranges of thermal conductivity values are necessary just to determine if a thermal test is warranted.

### Conclusion

**G**eothermal heat pumps offer substantial energy and cost savings. But their benefits will only be realized through careful data monitoring that documents how well they perform against other heating systems, and that help installers optimize their potential. Portable data loggers offer inexpensive and highly detailed information collection that serves these ends.

### About Onset

Onset Computer Corporation has been producing small, inexpensive, battery-powered data loggers and embedded controllers since 1981, and has sold over one million loggers that are used around the world by over 65,000 customers. The company manufactures a broad range of data logger and weather station products that are used to measure temperature, humidity, light intensity, voltage, and a broad range of other parameters. Onset products are used widely in research, commercial, industrial, and educational applications.

### Onset Computer Corporation

[www.onsetcomp.com](http://www.onsetcomp.com)

(800) 564-4377 / (508) 759-9500

Fax: (508) 759-9100

[sales@onsetcomp.com](mailto:sales@onsetcomp.com)

<sup>4</sup> Omaha Public power District, "Geothermal Conductivity Testing," [www.oppd.com/prodconsump10g/groups/web/documents/webcontent/22\\_000742.pdf](http://www.oppd.com/prodconsump10g/groups/web/documents/webcontent/22_000742.pdf)